

GEN II SUPER™

Universal Fit Systems

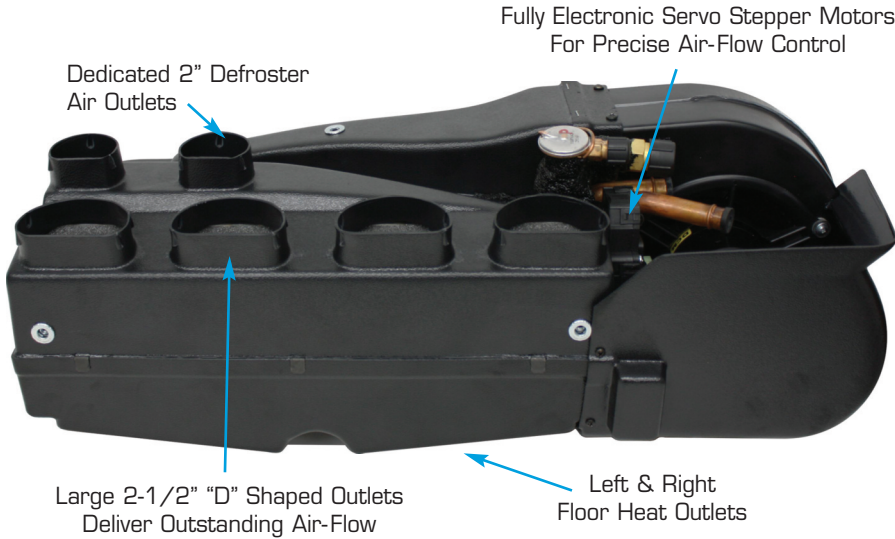

Gen II Universal Features:

- High torque gear-drive servo motors control all airflow doors for increased travel, greater airflow, superior door sealing, and immediate response to control input.
- No reliance on engine vacuum. Important with high performance engines!
- Our own engineered heating/cooling coils increase cooling capacity and heating capacity over other conventional designs.
- CAD designed and virtual modeled evaporator case design allows significant airflow volume increases over conventional designs.
- Superior air capacity and control of dedicated dehumidified defroster.
- Blower fan motor is isolated on rubber mounts for quiet running and longer life.
- Multiple control panel options.
- Heavy-duty wiring harness with circuit breakers and relays.
- Servo operated, adjustable heater control valve for variable temp adjustment.

61005-VUX-A Gen II Super - Heat & Cool

61005-VUZ-A Gen II Super - Heat, Cool & Defrost

Amazing performance is achieved with the Gen II Super's "D" shaped air outlets. As an added benefit, you can position all 4 louvers wherever you need them in or under your dash. The Super is an ideal system for larger sedans and wagons. Features true bi-level operation for cooling and heating modes and a more-powerful dedicated dehumidified defroster.

61005, 68000, 66005 Gen II Systems Include:

Evaporator unit, mounting brackets, wiring harness, electronic servo heater control valve, duct hoses, drain kit. Defrost kit option includes ducts and hoses.

Controls are ordered separately. See page 48.

Under hood components such as compressor, brackets, condenser, hose kit, drier, and optional upgrades are ordered separately from other sections in this catalog. See index on page 3.

Optional Components



605004-VUA - for Gen II Super
180° duct adapter for Super center vent.
Turns air flow down for under-dash louver use.

623013-VUA for Gen II Super
Smooth diverter duct for Super directs heater air to left side of car when evaporator is mounted to extreme right side. Accepts 2" hose.



Turn to page 48 for a complete display of Gen II control panel options.

GEN II Super

Top View

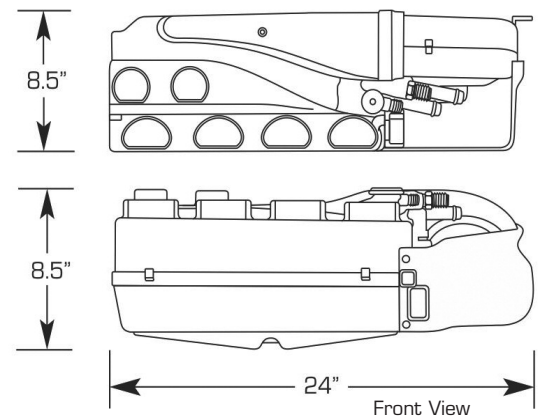

MANAGEMENT TEAM

Mike Martinez is our Production Manager. He has served well in many positions of responsibility over his 23 years with Vintage Air. Cross-training for all areas is a part of assuring that each of our managers understands the challenges of total quality manufacturing. Mike splits his driving between his '56 Chevy and an Arlen Ness Harley!

