

# GEN II COMPAC™ & MINI™

## Universal Fit Systems

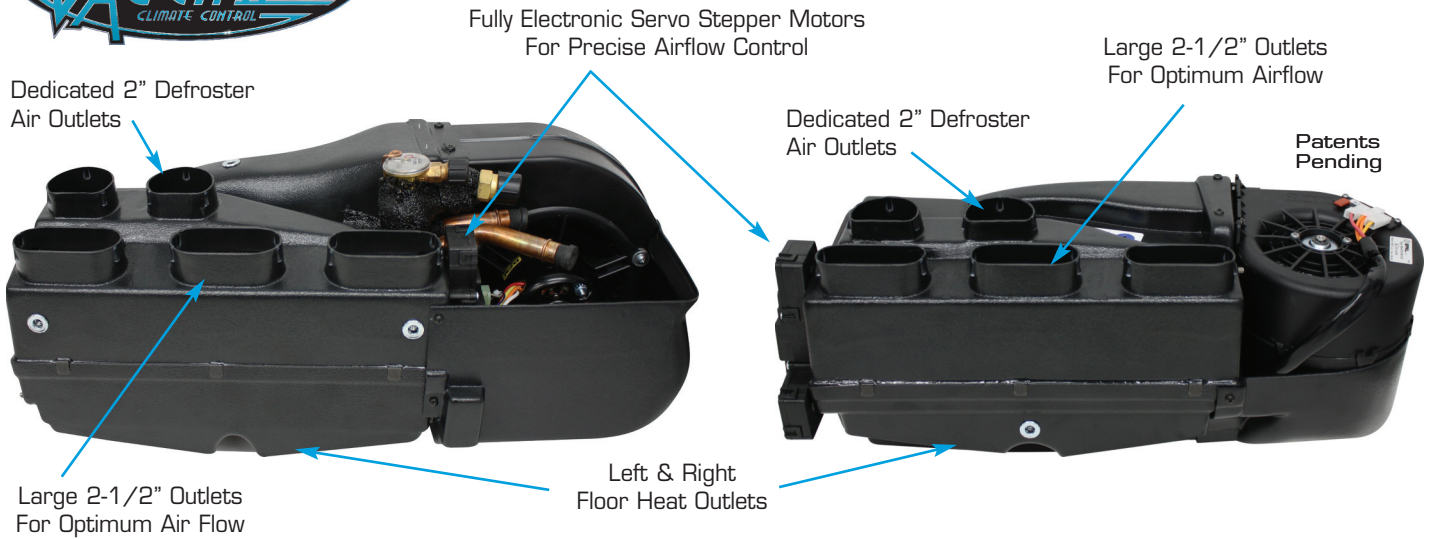

**68000-VUX-A** Gen II ComPac - Heat & Cool  
**68000-VUZ-A** Gen II ComPac - Heat, Cool & Defrost

Our proven Gen II servo motor control technology makes this mid-sized package work better than many other's full-size systems! Three outlet vents allow you to position your louvers wherever you need them. The Gen II ComPac is an ideal system for coupes, classic trucks and smaller sedans.

**66005-VUX-A** Gen II Mini - Heat & Cool  
**66005-VUZ-A** Gen II Mini - Heat, Cool & Defrost

Gen II technology is even incorporated into our smallest full feature heat & cool system. Exclusive CAD designed case delivers surprising capacity in an easy to fit package. The Gen II Mini is an ideal system for early model trucks and smaller hot rods.

### GEN II ComPac

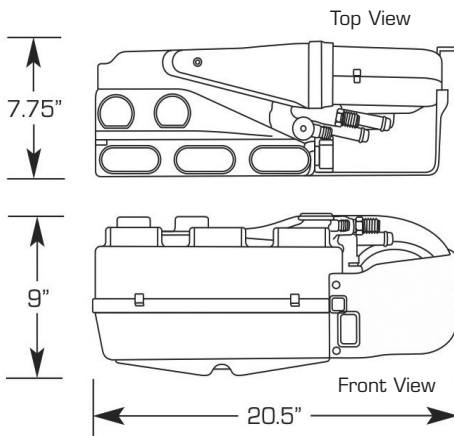

### Optional Components

**60500-VUA** - for Gen II ComPac & Mini 180° duct adapter for center vent. Turns air flow down for under-dash louver use.

**623000-VUA** - for Gen II ComPac & Mini smooth diverter duct directs heater air to left side of car when evaporator is mounted to extreme right side. Accepts 2" hose.

**623010-VUA** - for Gen II ComPac & Mini duct extension.

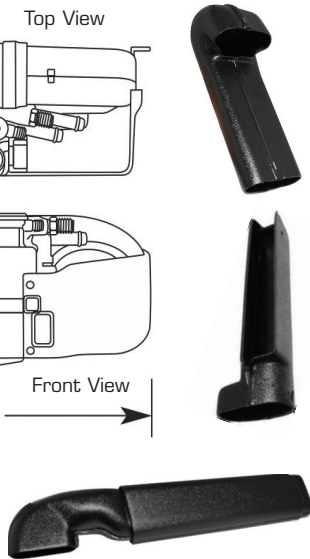

### GEN II Mini

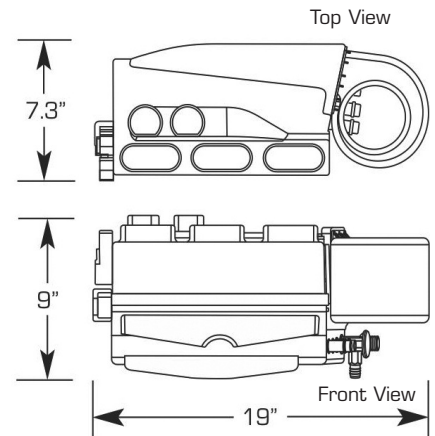

Ask your Authorized Distributor to loan you a Gen II Mock-Up Unit. Lightweight empty-case units will aid you in fitting a Gen II system in your car. See Page 42.

## TOTALLY COOLED GALLERY

Detroit Firemen's Fund, an organization of active and retired fire fighters, along with the help of numerous volunteers, rebuilt this 1937 Seagrave Safety Sedan for use in civic functions and funerals of fallen Michigan firefighters. The giant vehicle was restored to its fine original looks and the interior now seats entire families for its new duties. The Seagrave features a complete Gen II Super air conditioner in front and a Monster Trunk-Mount system in the rear area.

